

# Optical LANs Help Enterprises Go Green and Reduce Costs

When deploying local area networks (LANs), most enterprises juggle three, often conflicting, requirements. Budgetary constraints dictate the need to control both initial and long-term networking costs. Yet businesses also want to install the latest technology — in terms of network speed, functionality and security — in a way that enables the cost-effective evolution of networks in step with inevitable advances in technology. Finally, environmentally conscientious enterprises seek the greenest-possible route to achieving the other two objectives, namely by deploying LANs that reduce their organizations' energy consumption.

Fortunately it now is possible to achieve all three goals at the same time by deploying an advanced optical LAN that is based on gigabit passive optical networking (GPON) technology and packet optical transport. A solution such as Tellabs® Optical Enterprise, which combines the Tellabs® 7100 Optical Transport System (OTS) with the Tellabs® 1100 Multiservice Access Platform, delivers a “70-80-90%” set of benefits: reducing capital costs by up to 70%; reducing power consumption by up to 80%; and reducing by up to 90% the required floor, rack and closet space. It also paves a controlled, cost-effective migration path to new technologies and services, such as 40- and 100-Gbps transport and terabyte switching.

## A Closer Look at Optical LANs

Tellabs Optical LAN is a Layer-2 transport medium based on PON technology and fiber-optic cabling. It provides converged video, data and voice services at gigabit speeds over a single strand of fiber. Current GPON technology uses single mode fiber (SMF) as a medium for service delivery. SMF has a theoretical capacity to deliver bandwidth in excess of 50 terabits per second (Tbps), and extends the LAN reach up to 30 kilometers without signal regeneration. Compared with legacy active-Ethernet solutions, an optical LAN dramatically reduces both electronic and cabling requirements.

Also, optical LANs can help businesses make the most efficient use of existing network bandwidth. Sometimes enterprises, like their government-agency counterparts, use as little as 5 to 10% of link capacity. If businesses deploy dense wave division multiplexing (DWDM) technology, many use it only as “a dumb pipe” to interconnect routers. However, with an advanced optical LAN solution, they now can take advantage of more service intelligence in transport networks, such as the Layer-2 switching capabilities of the Tellabs 7100 OTS, to boost network efficiencies and still obtain the scalable bandwidth they need.

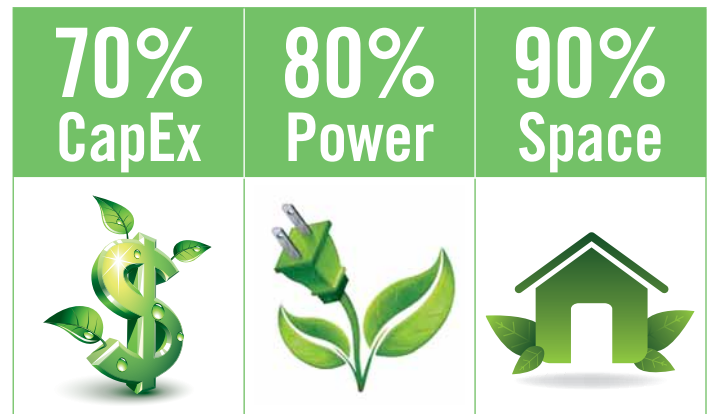

Tellabs Optical Enterprise provides 70-80-90% savings for service providers.

## ...and the Advantages of GPON Access

Similarly, many corporations and government agencies have not considered GPON, by now a mature technology, as an access solution. Yet its high-density, passive nature and all fiber-based infrastructure make an already cost-effective optical transport system even more so.

A solution such as the Tellabs® 1150 Optical Line Terminal (OLT), can support as many as 7,500 GigE ports, while the Tellabs® 1134 OLT, a smaller platform, can support 2,048 user ports. Many leading enterprises invest in both platforms because they want to deploy the technology in large and small offices. As an added bonus, such platforms deliver both native TDM and native packet services, which means an enterprise can eliminate its overlay networks and operate only 1 converged infrastructure.

Until recently, vendors had tailored GPON solutions to the residential market. However, the Joint Interoperability Test Command (JITC) within the U.S. Department of Defense now has certified one solution — the Tellabs Optical LAN — as government-ready. One of JITC's primary responsibilities is to ensure that products used by the military are secure, operate optimally in a multi-vendor environment, deliver exacting levels of performance under duress and offer unique features and functionality required for national security. Consequently, any optical LAN solution that can satisfy JITC's exacting requirements is well suited for the stringent requirements of enterprises as well.

### Proven Reliability Is Critical

Natural disasters, power outages, cable cuts and software problems can cripple telecommunications services. However, while those risks are manageable, the events of 9/11, Hurricane Katrina and increasing cyber-crime have heightened concern over network vulnerabilities. At the same time, more enterprises operate Voice over Internet Protocol (VoIP) networks and put voice, data and video on a single network.

Network downtime or degraded performance due to network issues, natural disasters or terrorist or criminal activities can now paralyze operations. Thus, enterprises are looking for higher service levels, such as 99.999% availability, which equates to about 5 minutes of downtime per year. That compares with previous standards of 99.8%, which caused more than 17 hours of downtime per year — or about 200 times more. The Tellabs OLTs are already designed to meet the carrier class availability metrics and the Tellabs 7100 OTS has been measured in the field to exceed them, delivering 99.9999% availability, or approximately only 30 seconds of downtime annually.

### Enhanced Security Also is Essential

GPON technology offers enterprise users highly secure communications, both upstream and downstream, because optical fiber makes wiretapping and hacks difficult. In addition, solutions such as the Tellabs 1150/1134 platform provide powerful security measures at the physical layer, data layer and end-user port. This greatly reduces the potential for Denial of Service (DoS), redirects or other malicious attacks.

Advanced GPON solutions feature mechanisms such as Access Control Lists (ACLs); Broadcast Datagram Rate Limiting at each end-user device; and strong authentication. ACLs enable enterprises to permit and/or deny, statically and/or dynamically, datagrams based on Layer 2 (Ethernet) rules, Layer 3 (IP) rules, and Layer 4 (TCP/UDP) rules. Flexible authentication mechanisms include 802.1x and DHCP Option 82. Authentication based on 802.1x enables multiple end-devices per end-user port, along with advanced intrusion detection. This method, upon detection of an untrusted device, effectively locks down the physical port.

### Different Costs Stem from Different Architectures

Before examining some of the specific cost differences between active-Ethernet LANs and optical LANs, it is helpful to look at differences in their architectures, the ones that produce the cost variances.

Within the active-Ethernet LANs deployed throughout enterprises and government agencies, Category 3/5 copper cables typically connect 3 layers of routers and switches. A router on the top-most layer links to campus- or building-aggregation switches on the next level down. In turn, these switches connect further down to communications closets, from which links then extend out to a pool of end-users.

An optical LAN solution also has a router at the top-most layer, but it does not need the campus- and building-aggregation switches, nor the communications closets. Instead, a single-mode fiber, typically equipped with a 1x32 splitter, runs between the router and OLT to the ONT(s) serving end-users.

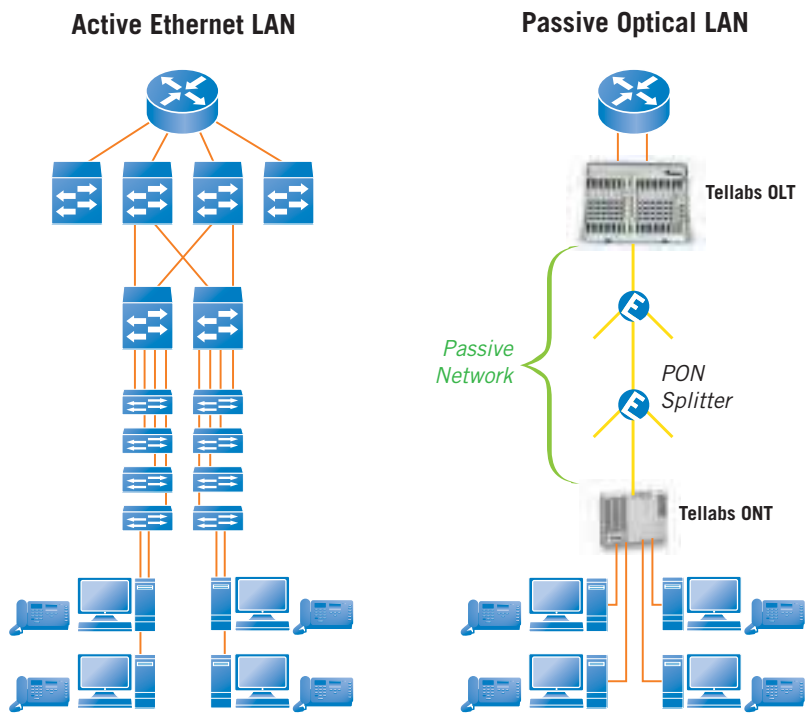

Active Ethernet LAN architecture versus a passive optical LAN architecture.

**Figure 1. Fiber-to-the-Desktop**

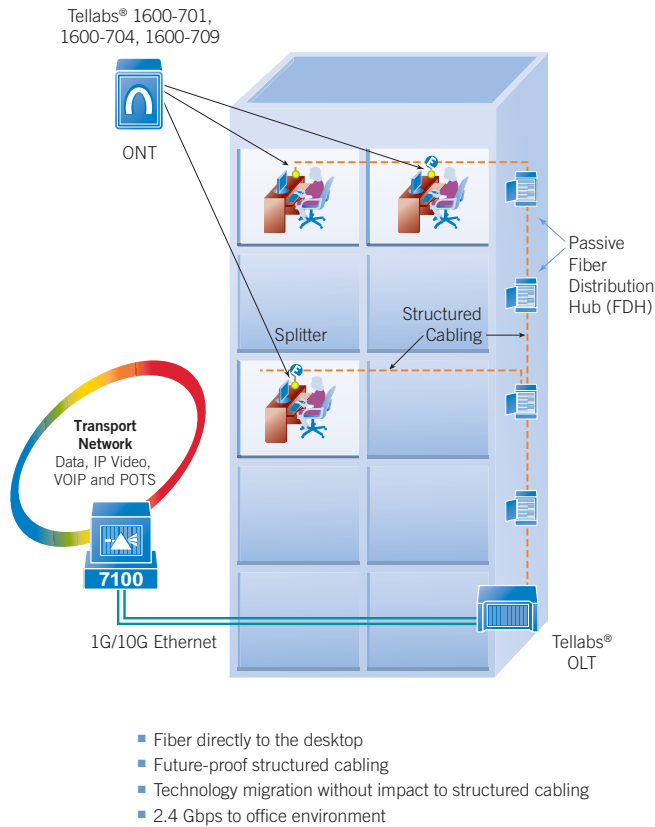

## Optical LANs Save Money on Several Fronts

Compared with the widely-deployed active-Ethernet LAN architecture, an optical LAN solution offers significant cost advantages. For example, in a fiber-to-the-desk (FTTD) LAN serving 2,000 users, the capital expenditure (CapEx) cost of building an active-Ethernet LAN typically is more than US \$1 million. An optical-LAN architecture can reduce that CapEx cost by more than 70%. See Figure 1.

When it comes to power consumption, an optical LAN is by far the “greener” — and more cost-effective — solution. In that same FTTD LAN serving 2,000 users, an active-Ethernet architecture consumes more than 10 watts per user, while the optical LAN consumes less than 2 watts per user. Using the U.S. Department of Energy’s estimated 2009 commercial rate of 10.5 cents per kilowatt hour, an optical LAN solution trims power-consumption costs by more than 80%, compared to an active-Ethernet LAN. Further, the

optical LAN’s annual operating expenditures (OpEx) for utility costs are \$72,000 lower than those of an active-Ethernet network. This savings figure can more than double when considering additional expense for HVAC power consumption, power distribution, and the cooling for communications rooms no longer needed.

Physical space is an expensive asset in any enterprise, and every organization wants to make the most efficient use possible of that valuable real estate. While the active-Ethernet LAN cited above requires 265 rack units, the optical LAN, with its high-density OLT, needs only 29 rack units, meaning it occupies 89% less physical space.

In another example, a typical active-Ethernet LAN serving about 2,000 users requires 90 rack units. Because most active-Ethernet LAN switches require 1 rack for the switch and 2 additional racks for running the large bundles of copper cables, that same active-Ethernet LAN would take 18 equipment racks. However, an optical LAN serving about 2,000 optical network terminals (ONTs) and 7,700 end users requires only 1 equipment rack using 9 rack units — again because of the high-density OLT.

To augment the CapEx, power and space savings in the Access network afforded by GPON, deploying the Tellabs 7100 OTS for packet optical transport for larger campuses or higher bandwidth locations provides additional savings. While providing virtually unlimited bandwidth with up to 88, 40Gbps channels over DWDM today, the Tellabs 7100 saves up to 60% in CapEx and OpEx by eliminating network elements such as distribution Layer 2 switches and SONET ADMs for further efficiencies in power, space and ongoing maintenance. Extensive technology integration gives the Tellabs 7100 the ability to converge traffic demands onto a single high speed infrastructure.

## A Longer LAN Reach Trims Even More Costs

An optical LAN saves even more money because it requires fewer communications closets, in some cases eliminating them altogether. Within an active-Ethernet LAN, the 100-meter distance limitation of the Category 3/5/5E/6 cabling basically forces an enterprise to deploy repeaters or switches across the building or campus. Because the single-mode fiber used in an optical LAN can reach as far as 30 kilometers, the enterprise can:

- Reduce or eliminate repeaters, switches and communications closets
- Deploy an OLT in a single, central location
- Link that single OLT to each and every end user in the building and across the campus
- Aggregate multiple OLTs across a campus further eliminating expensive router ports

As a result, enterprises can use valuable physical space formerly devoted to the active-Ethernet LAN for other purposes while reducing space-related costs. See Figure 2.

### Preserve Embedded Investments and Save Still More Money

A fiber-to-the-communications-closet deployment serving nearly 3,000 LAN users provides another illustration of the cost differences between an active-Ethernet LAN and an optical LAN. If IT managers opt to retain an enterprise's installed copper cabling, they must deploy an access device in the communications closet and link that to a central switch. The CapEx costs associated with the active-Ethernet solution exceed those of the optical LAN solution by more than \$1 million. In other words, the optical LAN trims by about 50% the CapEx costs incurred by the active-Ethernet LAN.

The optical LAN produces even more savings when it comes to the cost of power consumption. As noted earlier, with each user of an active-Ethernet LAN consuming more than 10 watts, and each user of an optical LAN consuming less than 2 watts, the optical LAN reduces power-consumption costs by more than 80%.

Further, while an active-Ethernet LAN in that fiber-to-the-closet deployment requires 210 rack units, the optical LAN needs only 150, which means the optical LAN occupies a physical space that is 29% smaller. A comparison of the annual OpEx for utility costs for the two architectures shows the optical LAN saves the enterprise \$54,000.

### Reduce the Total Cost of Ownership

Reducing the total cost of ownership (TCO) is a high priority for every enterprise, and the carrier-class design of an optical LAN can bring TCO down dramatically. For example, there is no need to swap out expensive Ethernet LAN switches every 5 to 7 years, as enterprises must do with legacy LAN architectures. Such a technology refresh involves numerous tasks, including:

- Engineering for the new network design
- Site surveys
- Bid generation, review and award
- Contract negotiations
- CapEx investments in significant platform upgrades or change-outs
- Program management
- Time and labor costs incurred by the actual installation.

In addition, when enterprises replace switches, they must also evaluate their cabling infrastructure to determine if it must change. Newer switches operate at speeds faster than most installed cabling can support.

Replacing the LAN cabling is a recurring, massive and expensive undertaking. To make a bad situation worse, each time the enterprise replaces its Category N cabling with Category N+1

**Figure 2. Fiber-to-the-Communication Closet**

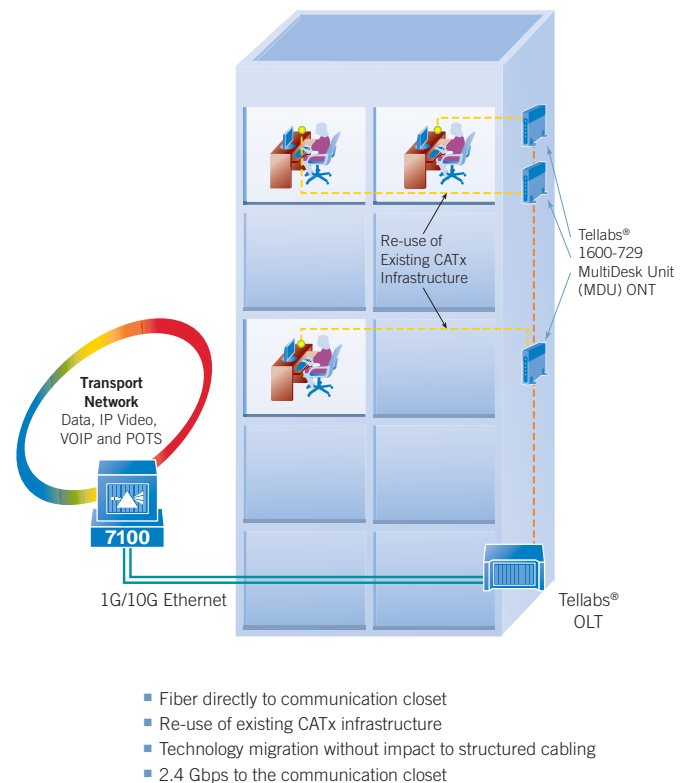

cabling, it basically trades one bandwidth-limited media for another. According to the Institute of Electrical and Electronics Engineers (IEEE) standards, while Cat5 cabling supports 100 Mbps, Cat6 supports 1 Gbps over 30 meters, and Cat 6A extends that to 100 meters. Although limitations on speed and distance are decreasing, they have by no means disappeared.

Fiber, by contrast, can deliver practically unlimited bandwidth — more than 50 Tbps, — in the opinion of many optics engineers. So, why continue replacing copper when an enterprise can install fiber once and never have to replace it again? In addition, with OLTs now able to reach 20-30 kilometers, distance limitations no longer are a consideration. An enterprise can, for example, deploy in a single building 1 OLT that serves an entire campus.

With the ability to extend the network lifecycle to 10 years or more, an optical LAN makes possible:

- Gradual, more predictable costs for bandwidth upgrades over the full 10-year period
- Modest ongoing maintenance costs associated with fiber
- Seamless addition of more technology-based capabilities, such as WDM, 40- and 100-Gbps transport and terabyte switching.



## A True Enterprise Solution

An advanced optical LAN solution offers enterprises a broad array of built-in functionalities, among them integrated Ethernet bridging; VLAN capability needed for network segmentation; and end-user authentication and security filtering. Because it functions much like an Ethernet switch, such an advanced solution makes it possible for an enterprise to replace an Ethernet-switched LAN seamlessly.

By changing out legacy LANs with optical LANs based on GPON and packet optical transport technology, enterprise organizations can easily:

- Obtain the LAN speeds, capacity and functionalities they need
- Gain control of their CapEx and OpEx, both initially and over the long term
- Fulfill their “go-green” objectives

Equally important, by deploying a solution such as the Tellabs Optical Enterprise, they can lay the technology foundation necessary to satisfy communications requirements well into the next decade.

## About Tellabs

Tellabs innovations enable the mobile Internet and help our customers succeed. That's why 43 of the top 50 global communications service providers choose our mobile, optical, business and services solutions. We help them get ahead by adding revenue, reducing expenses and optimizing networks.

Tellabs (Nasdaq: TLAB) is part of the NASDAQ Global Select Market, Ocean Tomo 300™ Patent Index, the S&P 500 and several corporate responsibility indexes including the Maplecroft Climate Innovation Index, FTSE4Good and eight FTSE KLD indexes. [www.tellabs.com](http://www.tellabs.com)

### North America

Tellabs  
One Tellabs Center  
1415 West Diehl Road  
Naperville, IL 60563  
U.S.A.  
+1 630 798 8800  
Fax: +1 630 798 2000

### Asia Pacific

Tellabs  
3 Anson Road  
#14-01 Springleaf Tower  
Singapore 079909  
Republic of Singapore  
+65 6215 6411  
Fax: +65 6215 6422

### Europe, Middle East & Africa

Tellabs  
Abbey Place  
24-28 Easton Street  
High Wycombe, Bucks  
HP11 1NT  
United Kingdom  
+44 871 574 7000  
Fax: +44 871 574 7151

### Latin America & Caribbean

Tellabs  
1401 N.W. 136th Avenue  
Suite 202  
Sunrise, FL 33323  
U.S.A.  
+1 954 839 2800  
Fax: +1 954 839 2828

The following trademarks and service marks are owned by Tellabs Operations, Inc., or its affiliates in the United States and/or in other countries: TELLABS®, TELLABS and T symbol®, and T symbol®. Statements herein may contain projections or other forward-looking statements regarding future events, products, features, technology and resulting commercial or technological benefits and advantages. These statements are for discussion purposes only, are subject to change and are not to be construed as instructions, product specifications, guarantees or warranties. Actual results may differ materially. The information contained herein is not a commitment, promise or legal obligation to deliver any material, code, feature or functionality. It is intended to outline Tellabs' general product direction. The development, release and timing of any material, code, feature or functionality described herein remains at Tellabs' sole discretion.