

The Business Case for Pseudowires in the RAN

Paul Momtahan
 Director of Data & Transport
 Solutions Marketing

As demand for mobile data services increases, controlling backhaul costs becomes the key to maintaining margins. By decoupling the transmission media from the mobile transport protocols, pseudowires enable mobile operators to decouple backhaul bandwidth from cost.

Executive Summary

The rising demand for mobile data services enabled by High-Speed Downlink Packet Access (HSDPA) is driving a dramatic increase in backhaul bandwidth requirements, from 2-6 Mbps per cell site to 20 Mbps and beyond. However, given the price-sensitive nature of these services in addition to voice pricing pressures, revenue increases for mobile operators are expected to be modest. The key to maintaining margins and profitability is to leverage the availability of low-cost transmission technologies, such as Ethernet and Digital Subscriber Line (DSL), while introducing statistical gain as a technique to reduce bandwidth requirements from aggregation points in the Radio Access Network (RAN). The problem is that today's mobile transport protocols, Time Division Multiplexing (TDM) for 2G and Asynchronous Transfer Mode (ATM) for R99/R4 3G, cannot be transported natively over packet-based transport technologies.

Pseudowire-enabled Multiservice Routers (MSR) provide a solution. MSRs leverage next generation silicon to combine the functionality of an ATM switch, an Ethernet switch and an Internet Protocol/ Multiprotocol Label Switching (IP/MPLS) router into a single network element. By decoupling the transmission media from the mobile transport protocols, pseudowires enable mobile operators to leverage the most cost-effective transport option on each link in the RAN, while also enabling statistical gain and providing a migration path to IP.

This white paper examines the business case for pseudowires and MSRs in a number of Global System for Mobile Communications (GSM) and Universal Mobile Telecommunications System (UMTS)

RAN scenarios and suggests a process to evaluate the business case for pseudowires in your RAN. A variety of connectivity options between RNC sites, hub sites and cell sites are covered (Figure 1):

- Ethernet to the hub site
- Ethernet to the cell site
- Hybrid DSL
- Ethernet microwave
- RNC site grooming

The RAN Bandwidth Explosion

With mobile voice revenues in mature markets forecast to start declining in the near future (Figure 2), due to a combination of subscriber saturation, price competition, Voice over Internet Protocol (VoIP) and regulatory pressure, mobile operators are positioning data services to increase their Average Return Per User (ARPU), reduce customer churn and become a driver for increased revenues and profits.

According to the report *Strategies for Creating End User Demand for Mobile Data Services* (Portio Research, 2006), mobile data applications gaining traction with subscribers include:

- Music downloads: UK-based mobile operator '3' has captured four percent of singles download sales in the UK and 17 percent of overall download activity

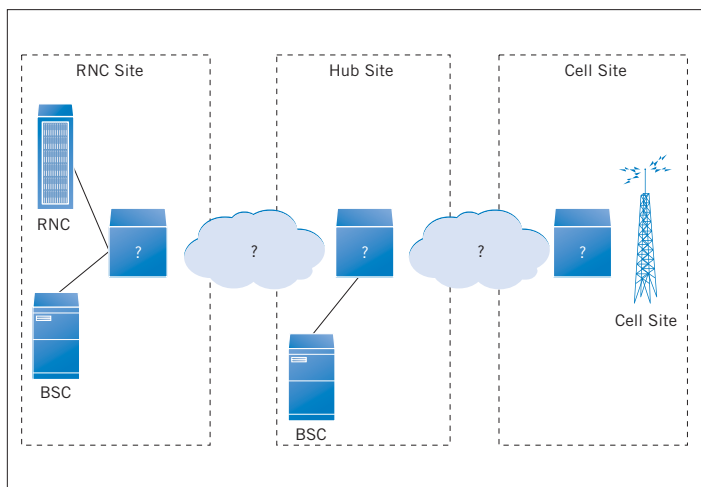

Figure 1. GSM/UMTS RAN architecture: RNC site — hub site — cell site

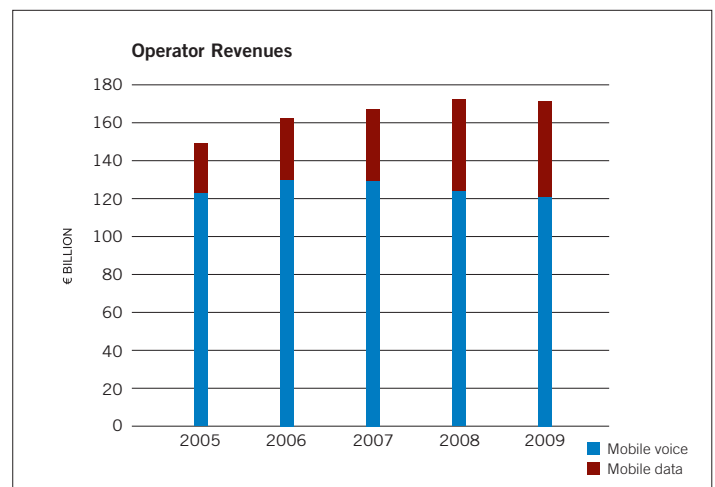

Figure 2. Mobile revenues in W. Europe (Source: Analysys, 2006)

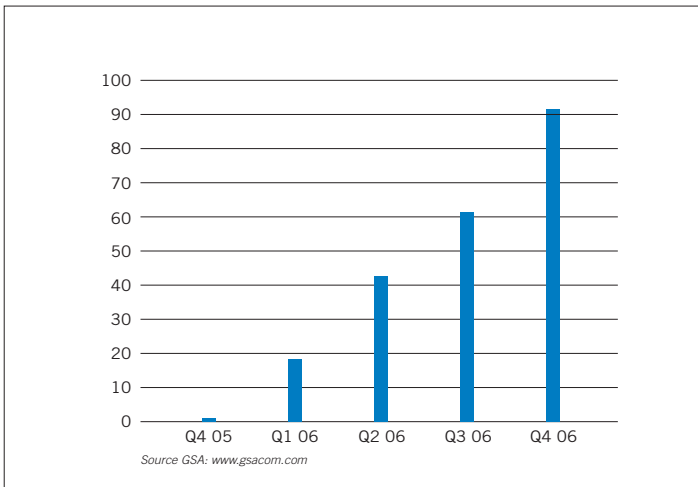

Figure 3. Cumulative commercial HSDPA launches (Source: GSA, January 2007)

- Video downloads: Mobile phone users are expected to spend more than \$1.5 billion on mobile video downloads and streaming in 2007
- Mobile portals: NTT's i-mode had 46.36 million subscribers in Japan as of 31 March 2006, representing market penetration of about 90% among NTT mobile subscribers
- MMS/Email: The volume of MMS messages for French mobile operator SFR increased from 6M in 2003 to 83M in H1 2006 alone
- “MoBlogging”: 34 percent of Americans aged 18-24 have used mobile phones to take and upload photos to weblogs
- Gaming (both downloads and online gaming): The worldwide market for mobile gaming exceeded \$3 billion in 2006

To meet this requirement, mobile operators are upgrading their UMTS 3G networks to support HSDPA, as shown in Figure 3. A recent Global mobile Supplier Association (GSA) survey revealed that as of January 2007 there had been 94 commercial launches in 54 countries or territories, and an additional 45 operators had plans to launch HSDPA, bringing the total number of HSDPA commitments to 139 in 62 countries.

Backhaul Bandwidth Growth

Supporting these new high bandwidth data services while meeting customer expectations, however, will require a large increase in backhaul capacity as the amount of bandwidth to each cell site scales from between 2 Mbps and 6 Mbps today to up to 20 Mbps and beyond.

As shown in Figure 4, even at low usage levels 6 Mbps backhaul is required to support HSDPA peak data rates of 3.6 Mbps on a three-sector cell. As the number of users and download volumes per month increase, backhaul capacity required for HSDPA alone can scale to over 14 Mbps. Add in another 2 Mbps for 2G and an additional 4 Mbps for 3G voice, and the total backhaul capacity to a single cell site could easily require 20 Mbps or more.

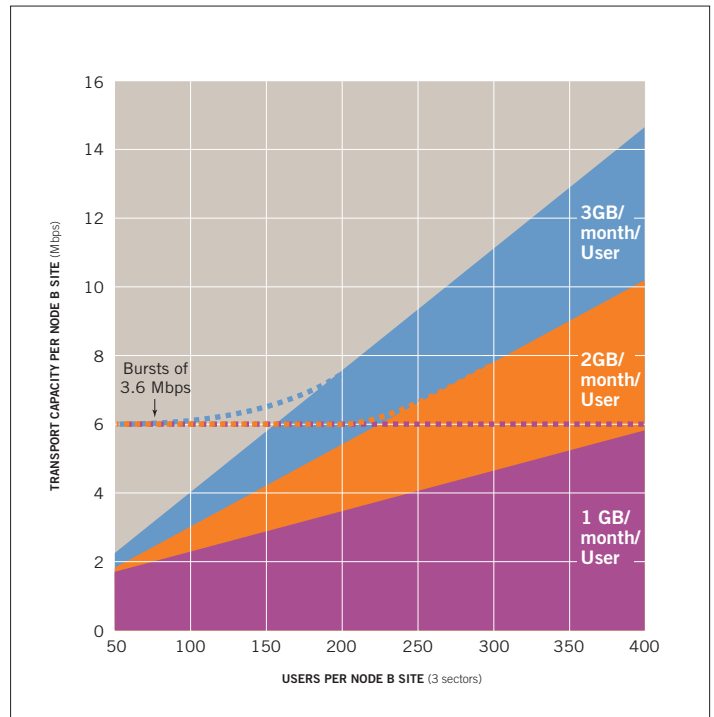

Figure 4. HSDPA backhaul requirements (Source: Tellabs modelling)

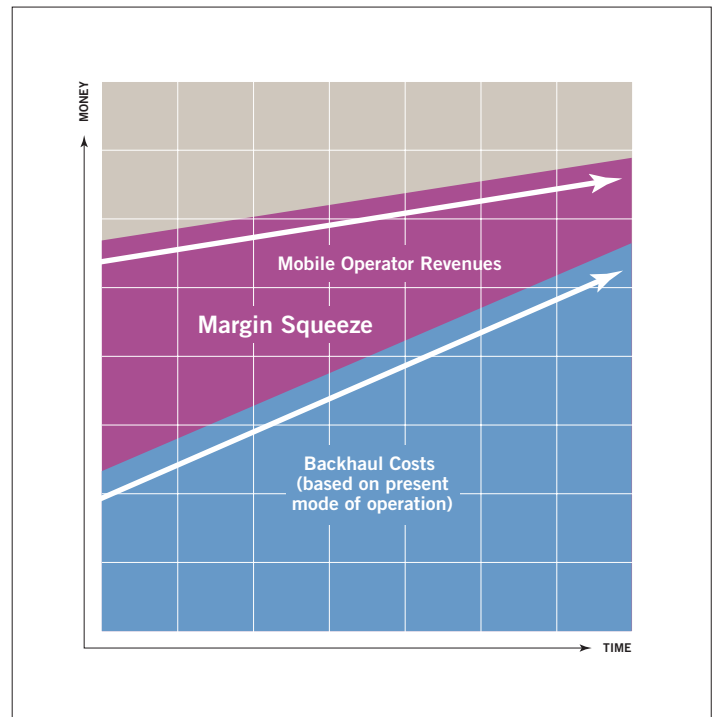

Figure 5. Mobile operator revenues vs. backhaul costs

The RAN Transport Dilemma

Based on legacy technologies and services such as T-1/E-1 TDM leased line services, TDM microwave, SONET/SDH transport equipment and legacy ATM switches, there is a fairly linear relationship between cost and bandwidth in the RAN. As bandwidth increases, cost increases as well, and there are few economies of scale to ease the expense.

This large increase in backhaul capacity driven by increased demand for mobile data services would not be a cost challenge if mobile operators could benefit from an equivalent increase in revenues to cover the costs. However, as shown in Figure 5, with the adoption of these new services typically very price-sensitive, HSDPA is expected to result in only incremental increases in mobile operators revenues.

Therefore, the only solution is to decouple bandwidth from cost. The question is how?

The Economics of Packet-based Transport

One solution to the increased bandwidth versus increased costs and reduced margins quandary is to use more economical packet-based services like Ethernet and DSL. As shown in Figure 6, Ethernet services have gained significant traction in the enterprise services market over the last five years, taking share from both leased line and ATM/Frame Relay services.

According to the 2004 Heavy Reading *Enterprise User Survey of Ethernet Service*, the top benefits of using carrier Ethernet services were ranked:

1. Delivers more bandwidth per dollar/euro
2. Offers the simplicity and familiarity of Ethernet
3. Supports very high bandwidth WAN connections
4. Provides the ability to upgrade bandwidth quickly
5. Eliminates the need for expensive WAN interfaces
6. Provides the ability to get the exact bandwidth needed

While two of these benefits — simplicity and familiarity of Ethernet and elimination of the need for expensive WAN interfaces — may be less relevant to mobile operators given that Ethernet interfaces are not yet widely available on BSCs, RNCs, BTS or NodeBs, the other benefits cited are all likely to be very attractive to mobile operators.

| | Typical Annual Rental | Typical Annual Rental Per Mbps |
|--------------------------------|-----------------------|--------------------------------|
| Last Mile (Cell to Hub) | | |
| E-1 | €5,000 (\$6,500) | €2,500 (\$3,250) |
| 10Mbps Ethernet | €12,000 (\$15,600) | €1,200 (\$1,560) |
| 100Mbps Ethernet | €16,000 (\$20,800) | €160 (\$208) |
| Metro (Hub to RNC) | | |
| STM-1 | €100,000 (\$130,000) | €670 (\$871) |
| Gigabit Ethernet | €50,000 (\$65,000) | €50 (\$65) |

Table 1. Typical pricing for leased lines/Ethernet in W. Europe (Tellabs estimates)

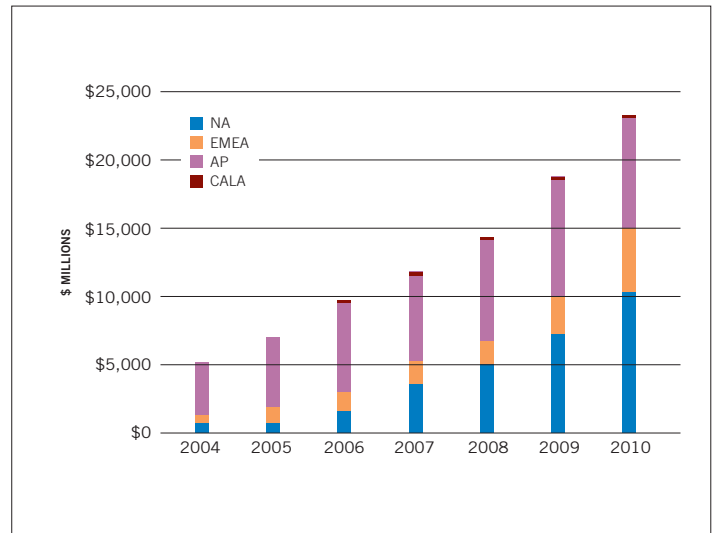

Figure 6. Global Ethernet services revenues (Ovum-RHK, 2006)

As shown in Table 1, a short-distance 10 Mbps Ethernet service in Western Europe is typically less than three times the cost of an E-1, while 100 Mbps Ethernet service is less than four times the cost of E-1. In some markets, Ethernet is even more attractively priced. One European mobile operator’s presentation at the Carrier Ethernet World Congress in September 2006 stated that they were using 10 Mbps Ethernet at a cost only 30 percent more than a 2 Mbps E-1 — gaining 400 percent more bandwidth for just 30 percent more cost.

Between the hub site and RNC site in the metro, price/performance can be even more compelling. Gigabit Ethernet is often available for less than half the cost of an STM-1, offering a greater than 10x increase in price/performance.

Another option is ADSL, offering up to 8 Mbps and widely available for between \$20 - \$40 USD or euros per month. Even if this cost doubled, considering the contention ratios and repair time required, DSL still presents a compelling cost advantage to mobile operators, particularly when used for lower priority data traffic (Table 2).

| | Typical Annual Rental | Typical Annual Rental Per Mbps |
|----------------------------------|-------------------------------|--------------------------------|
| 2Mbps E-1 (Europe) | \$6,500 (€5,000) | \$3,250 (€2,500) |
| T-1 (North America) | \$4,000 (€3,076) | \$2,666 (€1,538) |
| Residential ADSL (6Mbps) | \$30 (€23) x12 = \$360 (€277) | \$60 (€46) |
| ADSL for Mobile Operators | Residential x2 = \$720 (€554) | \$120 (€92) |

Table 2. T-1/E-1 vs. ADSL for mobile operators (Tellabs Estimates)

Ethernet microwave also offers significant economic benefits over TDM microwave, especially when combined with adaptive modulation, and typically delivers four times the bandwidth or better for the same or lower cost.

Leveraging metro Ethernet, DSL and Ethernet microwave presents the opportunity to significantly improve the price/performance of mobile backhaul networks.

The Economics of Statistical Gain

An additional way to improve the price/performance of mobile backhaul, in particular 3G data, is through statistical gain. Statistical gain works on the principle that not all users will be using the data network simultaneously. Extrapolating these usage patterns to the level of cell sites — not all cell sites will require their peak backhaul capacity simultaneously. Therefore, there is the opportunity for multiple cell sites to “share” 3G data backhaul capacity from a hub site back to the RNC site.

For HSDPA traffic the potential statistical gain ratio is typically between 10:1 and 5:1. Given that HSDPA traffic is likely to account for the dominant portion of backhaul traffic, reducing HSDPA bandwidth requirements by 80 percent to 90 percent is likely to be a compelling benefit, assuming the cost of bandwidth is high relative to cost of the equipment required for statistical gain.

For example if a mobile operator has five E-1s for HSDPA, one E-1 for 3G voice, and one E-1 for 2G (totalling seven E-1s) at each cell site, then statistical gain on the HSDPA could reduce the backhaul capacity requirement to one E-1 for HSDPA, one E-1 for 3G voice, and one E-1 for 2G for a total of three E-1s, a reduction of 57 percent.

| | Physical E-1s per Cell Site | E-1s per Hub (10 Cell Sites) | # of STM-1s | Annual Cost |
|-----------------------|-----------------------------|------------------------------|-------------|----------------------|
| No Statistical Gain | 7 | 70 | 2 | €200,000 (\$260,000) |
| With Statistical Gain | 7 | 30 | 1 | €100,000 (\$130,000) |
| Saving with Stat Gain | — | 40 | 1 | €100,000 (\$130,000) |

Table 3. Example of statistical gain

As shown in Table 3, if the cost of an STM-1 is €100,000 (\$130,000) per year, then statistical gain would save the operator at least €100,000 (\$130,000) per year by eliminating the need to add a second STM-1 or upgrade to an STM-4. This scenario offers a compelling business case, assuming the cost of aggregation equipment is significantly less than €100,000 (\$130,000).

Introducing Pseudowires

Ethernet and DSL offer the promise of significant price/performance gains and, in the case of Ethernet, the additional benefit of fast bandwidth upgrades. However, today’s typical mobile networks are ill-equipped to take advantage of the benefits of Ethernet and DSL.

Today’s GSM 2G RANs are based on TDM backhaul with Frame Relay for Generic Packet Radio Service (GPRS) between the Base Station Controller (BSC) and Serving GPRS Support Node (SGSN). UMTS 3G RANs are based on ATM transport. While future UMTS releases will support IP in the RAN, these releases are unlikely to be a reality before 2009 and there will still be a vast installed base of 2G Base Transceiver Stations (BTS) and ATM-based NodeBs.

Therefore, the solution can be to decouple the mobile transport protocols from the transmission media. This is where pseudowires come in. MPLS pseudowires enable mobile operators to emulate TDM, Frame Relay and ATM circuits — in addition to Ethernet and IP — over the lowest cost transmission media, whether that is SONET/SDH/TDM, Ethernet, or DSL (Figure 7).

Following are individual business cases that explore using Ethernet and DSL in a number of GSM/UMTS RAN applications.

Ethernet to the Hub Site

In markets where leased lines are expensive and pricing is distance-sensitive, using hubs to aggregate shorter leased lines onto a high capacity trunk offers an attractive business case. In these cases, the savings from shorter E-1/T-1s to the cell site exceed the cost of aggregation equipment and trunk links. Using MSRs to deliver statistical gain can make this option even more attractive. While less popular in North America, hubbing is common in most other markets.

Where cost-effective metro Ethernet capacity is available between the RNC site and the hub site, MSRs can be used to emulate 3G ATM and 2G TDM circuits over metro Ethernet, as shown in Figure 8.

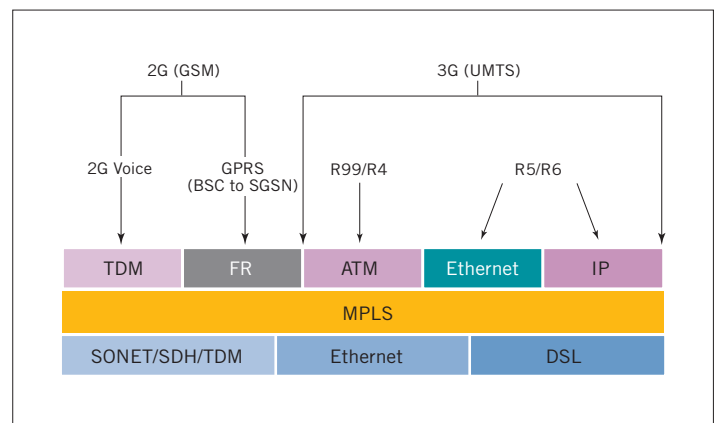

Figure 7. MPLS pseudowires for mobile transport in GSM/UMTS networks

As illustrated in Table 4, if current backhaul is handled via an STM-1 at the cost of €100,000 (\$130,000) per year, with a second STM-1 likely to be required soon due to anticipated strong growth in HSDPA traffic, an MSR could help in several ways. MSRs would not only reduce the capacity below 100 Mbps through statistical gain, but also would enable the mobile operator to use a 100 Mbps metro Ethernet service rather than deploy a second STM-1. This scenario delivers annual cost savings of €170,000 (\$221,000) — €34 million/\$44.2 million per year, per network of 10,000 cell sites — minus one-time MSR acquisition costs.

| | Capacity | STM-1s | 100M Ethernet | Annual Cost |
|------------------------------|----------|--------|---------------|------------------------------|
| STM-1 to the Hub Site | 175 Mbps | 2 | — | €200,000 (\$260,000) |
| Ethernet to Hub Site | 75 Mbps* | — | 1 | €30,000 (\$39,000) |
| Saving with Ethernet | | | | €170,000 (\$221,000) |
| Saving for 200 Hubs | | | | €34 million (\$44.2 million) |

Table 4. Ethernet to the hub site business case * Due to statistical gain

An additional benefit of moving to Ethernet is the ability to quickly increase bandwidth as required, even in small increments. Mobile operators avoid paying for unused capacity, yet can still meet performance expectations in the event of an unforeseen increase in demand.

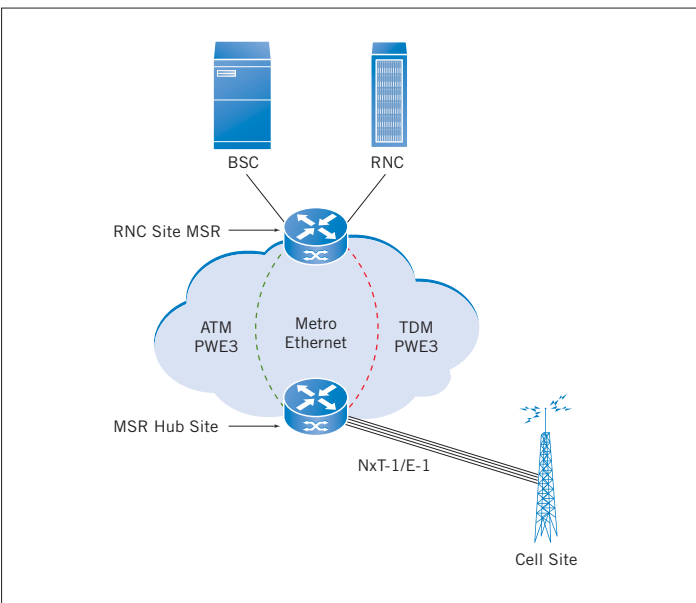

Figure 8. Ethernet to the hub site

Ethernet to the Cell Site

In networks where E-1/T-1 leased lines are currently used at the cell site and cost-effective Ethernet service is available — either over fiber or bonded copper — an even more compelling business case can be made for using MSRs to emulate 3G ATM and 2G TDM circuits, as shown in Figure 9.

In Table 5, we are assuming that an E-1 leased line costs €5,000 (\$6,500) per year, a 10 Mbps Ethernet costs €12,000 (\$15,600) annually, and the cost of 100 Mbps Ethernet is €16,000 (\$20,800) per year,

| | Capacity | E-1 | Ethernet | Annual Cost |
|--------------------------------|----------|---------------------|-------------------------|--------------------|
| E-1s to Cell Site | 10 Mbps | 5x€5,000 (5x 6,500) | — | €25,000 (\$32,500) |
| Ethernet to Cell Site | 10 Mbps | — | 1x€12,000 (1x \$15,600) | €12,000 (\$15,600) |
| Saving with Ethernet | | | | €13,000 (\$16,900) |
| Saving for 10,000 Sites | | | | €130M (\$169M) |

Table 5. Ethernet to the cell site business case

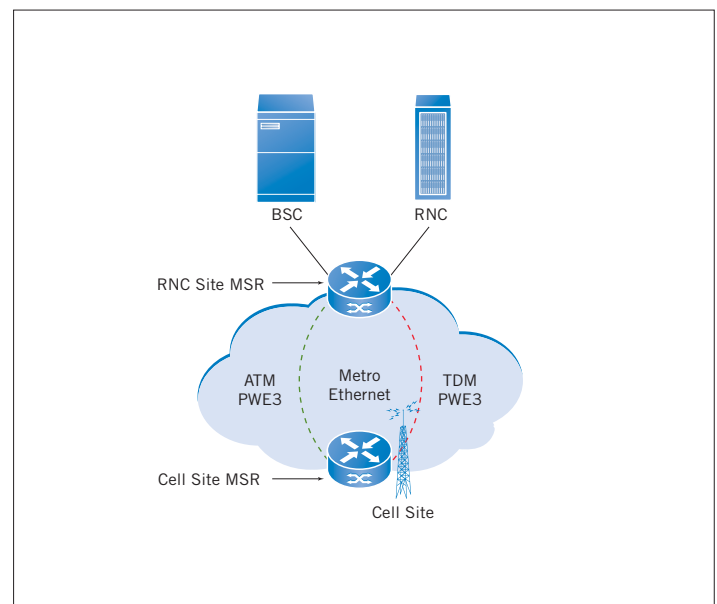

Figure 9. Ethernet to the cell site

the case for Ethernet looks positive once demand requires three or more E-1s to the cell site. Given that a minimum of 6 Mbps is needed to support 3.6 Mbps HSDPA on a three-sector cell, along with a typical minimum of an additional 2 Mbps for 3G voice and 2Mbps for 2G, the savings gained by using Ethernet to the cell site would be 5x €5,000 - €12,000 = €13,000 (5 x \$6,500 - \$15,600 = \$16,900) per year, per cell site, equivalent to €130 million (\$169 million) per year on a 10,000 cell site network, minus the one-time capital acquisition cost of the MSRs.

In reality, given the non-linear pricing of E-1/T-1 circuits (i.e., second E-1s/T-1s to the same cell site often costs less than the first), the actual savings might not be quite that high, but they are still likely to be very attractive, especially as the bandwidth required to each cell site scales to 20 Mbits (10 E-1s or 13 T-1s).

Hybrid DSL Backhaul

In situations where Ethernet is not available, hybrid DSL presents an attractive option for backhaul, especially in markets where TDM leased line pricing is high and DSL is available with acceptable contention ratios and repair time Service Level Agreements (SLAs).

In this scenario, the most attractive business case is likely to occur where expensive E-1/T-1 leased lines are being used. Given the reliability, symmetry and QoS limitations of DSL services, the best strategy is often to continue to use E-1s/T-1s for 2G and 3G voice while leveraging the price/performance of DSL for data services where SLA requirements are less stringent (Figure 10).

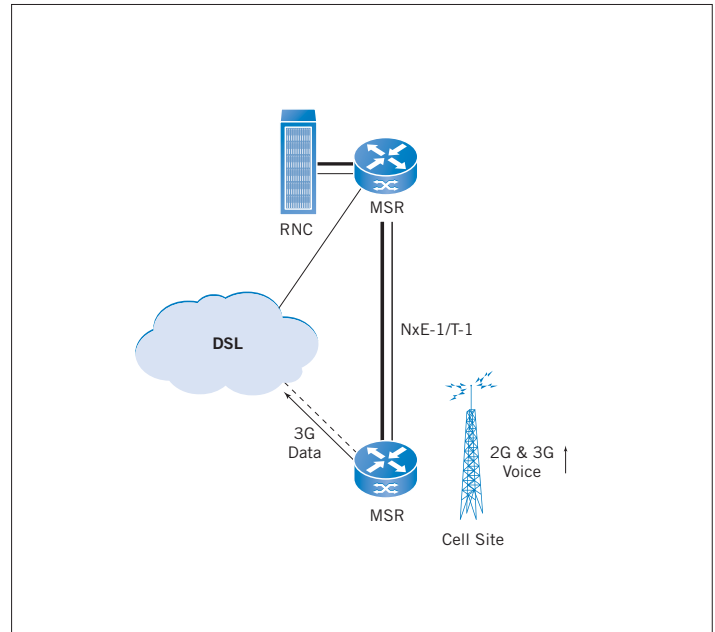

Figure 10. Hybrid DSL with E-1/T-1 leased lines

Using the previous example in which 10 Mbps was required at a cost of €25,000 (\$32,500) for five E-1s, a hybrid DSL approach with two E-1s (at a cost of €10,000/\$13,000) plus €554 (\$760) for DSL, would result in a total cost of €10,554 (\$13,760). This scenario would deliver savings of €14,446 (\$18,740) per year, per cell site — or €144 million (\$187 million) per year on a 10,000 cell site network, minus the one-time capital acquisition cost of the MSRs (Table 6).

Ethernet Microwave

Even where microwave is a very cost-effective solution, pseudowire technology still presents a strong business case. Ethernet microwave with adaptive modulation (Figure 11) offers the benefit of a 4x bandwidth increase for 99.9 percent of the time when environmental conditions are favorable, decreasing to 2x or 1x of the capacity in the 0.1 percent of time when environmental conditions may be less favorable. While adaptive modulation can work with TDM transport, Ethernet provides an elegant solution for handling bandwidth degradation by prioritizing traffic for QoS.

Using MSRs to transport ATM and TDM over Ethernet microwave with adaptive modulation typically offer four times the bandwidth or better for the same or lower cost.

| | Capacity | E-1 | DSL | Annual Cost |
|--------------------------------|----------|--------------------------|---------------------|------------------------|
| E-1s to Cell Site | 10 Mbps | 5x€5,000 (5x \$6,500) | — | €25,000 (\$32,500) |
| Hybrid DSL Case | 10 Mbps | 2x€5,000 (2x \$6,500) | 1x€554 (1x\$760) | €10,554 (\$13,760) |
| Saving with DSL | | | | €14, 446 (\$18,740) |
| Saving for 10,000 Sites | | | | €144M (\$187M) |

Table 6. Hybrid DSL business case

Using MSRs for ATM Grooming in Front of the RNC

ATM grooming in front of the RNC has been widely adopted by UMTS 3G mobile operators. ATM grooming reduces RNC costs by:

- Enabling more efficient usage of the RNC (typically a 100 percent improvement)
- Requiring fewer RAN-facing OC-3/STM-1 ports on the RNC and typically reducing the number of ports by two-thirds due to statistical gain
- Using unchannelized ports at a lower cost, generally half the cost of the channelized ports that would be required without ATM grooming.

Today the majority of mobile operators use ATM switches to perform grooming in front of the RAN. What role do MSRs play in this scenario?

- MSRs are typically significantly more cost-effective than ATM switches
- MSRs support transport over Ethernet, unlike ATM switches, so MSRs offer an attractive transport option as traffic increases and Ethernet services become more widely available
- MSRs offer a smooth migration path to an IP RAN — ATM switches either do not support IP routing or it is a very expensive upgrade with limited performance

The Economic Value of an IP-Ready RAN

Because MSRs provide a migration path to the all-IP RAN specified in the 3rd Generation Partnership Project (3GPP) Release 5 and Release 6 with Ethernet and IP pseudowires, MSRs are also ready to support the IP meshing requirements of Long Term Evolution (LTE) with IP VPN support. What economic value is delivered with this capability?

| | Solution A: IP-Ready MSRs | Solution B: Non-IP-Ready Solution |
|--------------|--------------------------------------|--|
| 2008 | \$10M | \$10M |
| 2009 | \$10M | \$10M |
| 2010 | \$10M | \$10M |
| 2011 | \$10M | \$10M |
| 2012 | Upgrade to IP routers = \$0 | Upgrade to IP routers = \$20M |
| Total | \$40M | \$60M |

Table 7. IP-ready MSR vs. non-IP-ready solution

Table 7 illustrates an evaluation of two solutions for the RAN. Solution A is implemented with IP-ready MSRs and Solution B, though equally capable of meeting short-term needs for the same initial acquisition cost, does not support IP routing or IP VPNs. In this example, the operator rolls out LTE in 2012, which requires IP VPN support in the RAN. If the operator has implemented Solution A, there is no upgrade cost. With Solution B, however, the previous investments in 2008

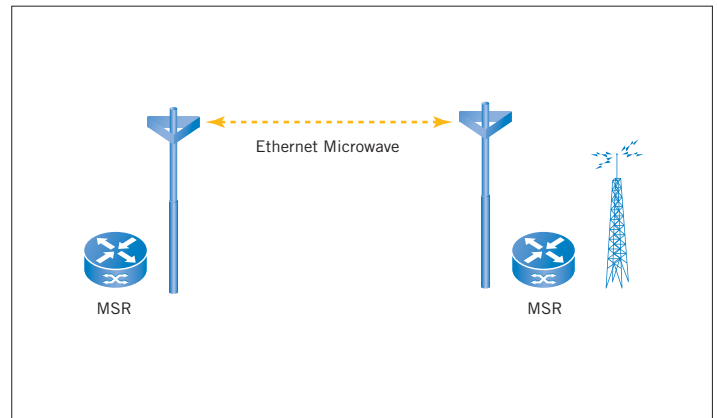

Figure 11. Pseudowire Backhaul over Ethernet Microwave

through 2011 will have to be scrapped and a new solution that is capable of supporting IP VPNs will need to be deployed.

Even if the cost of MSRs and IP routers should decrease by 50 percent between now and 2012, an upgrade would still result in additional cost with Solution B. An IP-ready MSR solution eliminates the need to incur significant additional costs for upgrades required to support LTE.

Furthermore, IP VPN support offers additional benefits in the short-term for management traffic, and in the medium-term for signaling and synchronization traffic, both of which deliver potential IP router Capital Expenditure (CapEx) savings.

The Role of SONET/SDH MSPPs

Despite the compelling business case for MSRs, SONET/SDH-based Multiservice Provisioning Platforms (MSPPs) still have an important role to play in the RAN.

The optimal mix of MSRs and MSPPs in the RAN is dependent on a number of factors, including:

- Cost of bandwidth
- Percentage of 3G data (HSDPA) and statistical gain
- Mix of E-1/T-1 interfaces and Ethernet interfaces required

For example, in hub applications in which the incremental cost of bandwidth is low and fiber is available (or there is little statistical gain possible) and the requirement is primarily to aggregate E-1/T-1s, a MSPP-based aggregation solution as shown in Figure 12 is likely to be the most cost-effective solution. Due to the lower complexity and economies of scale, the cost of an E-1/T-1 interface on a SONET/SDH platform is lower than an E-1/T-1 on a MSR, which has to support the additional complexity of TDM circuit emulation over packet or ATM processing.

Furthermore, as MSPPs support Ethernet pseudowires, they offer an option for migrating to an IP RAN as Ethernet interfaces become available on NodeBs and BTSs.

Building a Business Case for Pseudowires in the RAN

To build an optimal business case for pseudowires and MSR in the RAN:

1. Gather detailed information on the RAN, including the location and number of RNC/BSC sites, hub/cell sites, existing capacity, existing traffic, and traffic growth forecasts.
2. Forecast the cost of scaling the RAN to support traffic growth forecasts based on the present mode of operation costs.
3. Identify opportunities to use MSRs for Ethernet to the hub site, Ethernet to the cell site, hybrid DSL, Ethernet microwave, RNC site ATM grooming, and MSPPs for cost-effective E-1 aggregation — creating a micro business case for each opportunity.
4. Outline additional economic benefits of the new solution, including IP router cost savings, OpEx savings gained with a converged network featuring end-to-end management, and faster time to revenue with new service introductions.
5. Compare the combined cost savings delivered by MSRs (Step 3) and the added economic benefits (Step 4) with the cost of the present mode of operation costs (Step 2) to evaluate the business case.

Conclusion

By utilizing pseudowires and MSRs to decouple mobile transport protocols from transmission media, mobile operators can utilize the most cost-effective transport option for each link in the RAN. At the same time, they can leverage statistical gain and provide a migration path to an all-IP RAN. Assuming the availability of cost-effective Ethernet, DSL, Ethernet microwave and statistical gain, the business case is compelling.

Tellabs has extensive experience working with mobile operators to create business cases like these. For additional information about how we can help you develop the business case to optimize your RAN, please consult your Tellabs account manager or regional sales office.

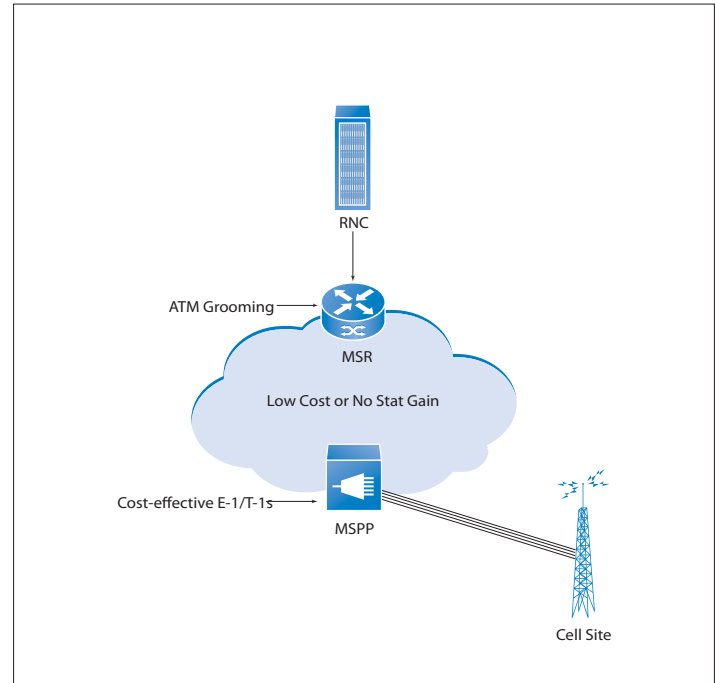

Figure 12. Cost-effective E-1/T-1 aggregation with MSPPs

North America

Tellabs
One Tellabs Center
1415 West Diehl Road
Naperville, IL 60563
U.S.A.
+1 630 798 8800
Fax: +1 630 798 2000

Asia Pacific

Tellabs
3 Anson Road
#14-01 Springleaf Tower
Singapore 079909
Republic of Singapore
+65 6215 6411
Fax: +65 6215 6422

Europe, Middle East & Africa

Tellabs
Abbey Place
24-28 Easton Street
High Wycombe, Bucks
HP11 1NT
United Kingdom
+44 870 238 4700
Fax: +44 870 238 4851

Latin America & Caribbean

Tellabs
1401 N.W. 136th Avenue
Suite 202
Sunrise, FL 33323
U.S.A.
+1 954 839 2800
Fax: +1 954 839 2828

Statements herein may contain projections or other forward-looking statements regarding future events, products, features, technology and resulting commercial or technological benefits and advantages. These statements are for discussion purposes only, are subject to change and are not to be construed as instructions, product specifications, guarantees or warranties. Actual results may differ materially.

The following trademarks and service marks are owned by Tellabs Operations, Inc., or its affiliates in the United States and/or other countries: TELLABS®, TELLABS and T symbol®, and T symbol®.

Any other company or product names may be trademarks of their respective companies.

© 2007 Tellabs. All rights reserved.
74.1827E Rev. A 5/07